

PROPOSED THREE STORIED RESIDENTIAL BUILDING PLAN AT MOUZA - LASKARPUR, J.L. No.- 57, R.S. DAG NO. - 76 / 1475, L.R. DAG NO.-493, R.S.KHATIAN. NO. - 39, L.R. KHATIAN NO.- 3198, WARD No.-30, HOLDING No.-21, RAMKRISHNA NAGAR, P.S.-NARANDRAPUR, DIST.-24 PARGANA(S). UNDER RAJPUR SONARPUR MUNICIPALITY. OWNERS' NAME SMT . KALPANA BOSE. AS CONSTITUTE ATTORNEY OF SRI. ASHOKE MUKHERJEE

DETAILS SPECIFICATION OF BUILDING

- 1: ALL DIMENSIONS ARE IN MILLIMETER UNLESS MENTION.
- 2: ALL EXTERNAL WALLS 200 M.M. THICK, EXCEPT OTHERWISE MENTIONED CONSTRUCTION WITH CEMENT - SAND MORTAR (1:6).
- 3: ALL PARTITION (INTERNAL) WALLS 125 & 75 M.M. THICK CONSTRUCTION WITH CEMENT-SAND MORTAR (1:4).
- 4: ALL PROJECTED CHAJJA SHALL BE 450 M.M. WIDE & 150 M.M. BEARING WITH EACH SIDE OF THE OPENING.

AREA OF LAND [AS PER DEED] 03 KA 00 CH 00 SFT. =	200.66 SQM.
AREA OF LAND [AS PER POSITION] 2 KA 15 CH 3 SFT =	196.79 SQM.
PERMISSIBLE GROUND COVERAGE =	65 %
PROPOSED GROUND COVERAGE =	58.59 %
PERMISSIBLE F.A.R. =	1.75
ROAD WIDTH =	3.66 M.
PERMISSIBLE BUILDING HEIGHT =	10 M.
PROPOSED BUILDING HEIGHT =	9.9 M.
PERMISSIBLE FLOOR AREA FOR F.A.R CALCULATION=(1.75 x 196.79)	344.38 SQM.

AREA CALCULATION:-

	A	B	C	D	E	F	G	H	I	J	K	L	M	N
TOTAL AREA	ELEC. DUCT	LIFT WELL	STAIR DUCT	ACTUAL AREA WITHOUT A-(B+C+D)	STAIR INSIDE AREA	LIFT LOBBY AREA	AREA EXCLUDING E-(F+G)	ACTUAL RESIDENTIAL AREA	AREA OF CARPARKING (SQM)	COMMERCIAL AREA	SERVICE AREA	PASSAGE AREA	F.A.R. CALCULATION N=(H-J)/LAND AREA	
(SQM.)	(SQM.)	(SQM.)	(SQM.)	(SQM.)	(SQM.)	(SQM.)	(SQM.)	(SQM.)	PERMISS	PROVIDE	(SQM.)	(SQM.)	(SQM.)	(SQM.)
GR. FL	112.83	0	0	0	112.83	10.08	0	102.75	74.75	25	15.89	10.53	1.58	0
1ST FL	115.29	0	0	0	115.29	10.08	0	105.21	105.21					
2ND FL	115.29	0	0	0	115.29	10.08	0	105.21	105.21					
TOTAL AREA	343.41	0	0	0	343.41	30.24	0	313.17	285.17	25	15.89	10.53	1.58	0

NO OF FLAT = 06 NO

PARKING AREA CALCULATION

FLOOR	RESIDENTIAL AREA (SQM)	REQUIRED PARKING	PARKING PROVIDE
GR. FLOOR	112.83 - 10.08 - 0 = 74.75		
1ST FLOOR	115.29 - 10.08 - 0 = 105.21	=285.17/250	1 NOS
2ND FLOOR	115.29 - 10.08 - 0 = 105.21	=1.141	
TOTAL		= 285.17	

SMT.KALPANA BOSE.
AS CONSTITUTE ATTORNEY OF
SRI. ASHOKE MUKHERJEE.

NAME OF OWNER .

ANIK MAJUMDAR
E.B.S. NO.- 839/I

NAME OF E.B.S.

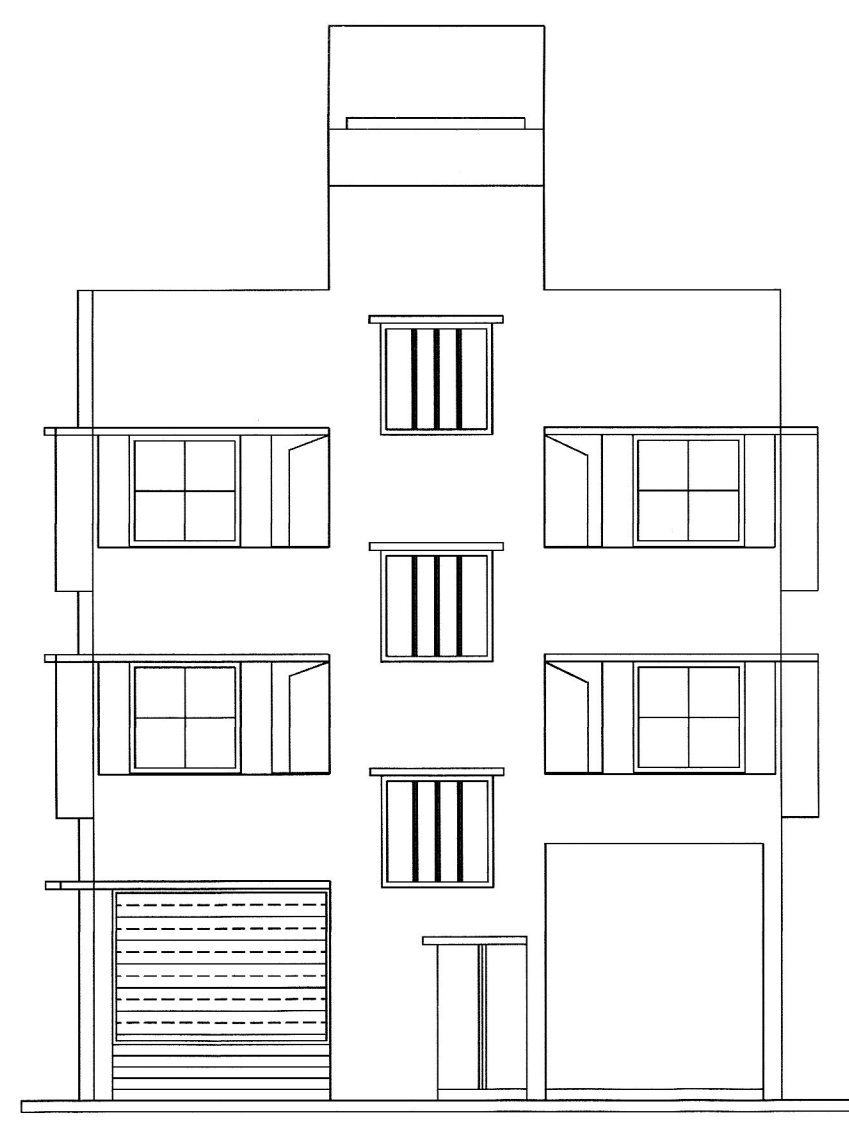

FRONT ELEVATION
SCALE - 1:100

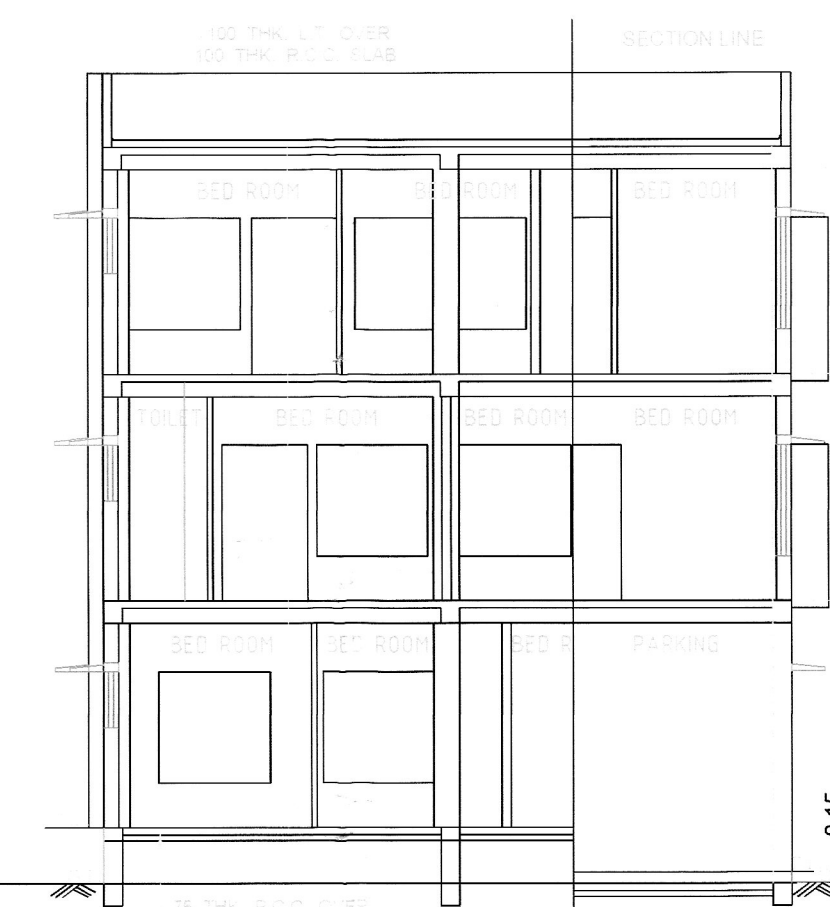

SECTION AT A - B
SCALE - 1:100

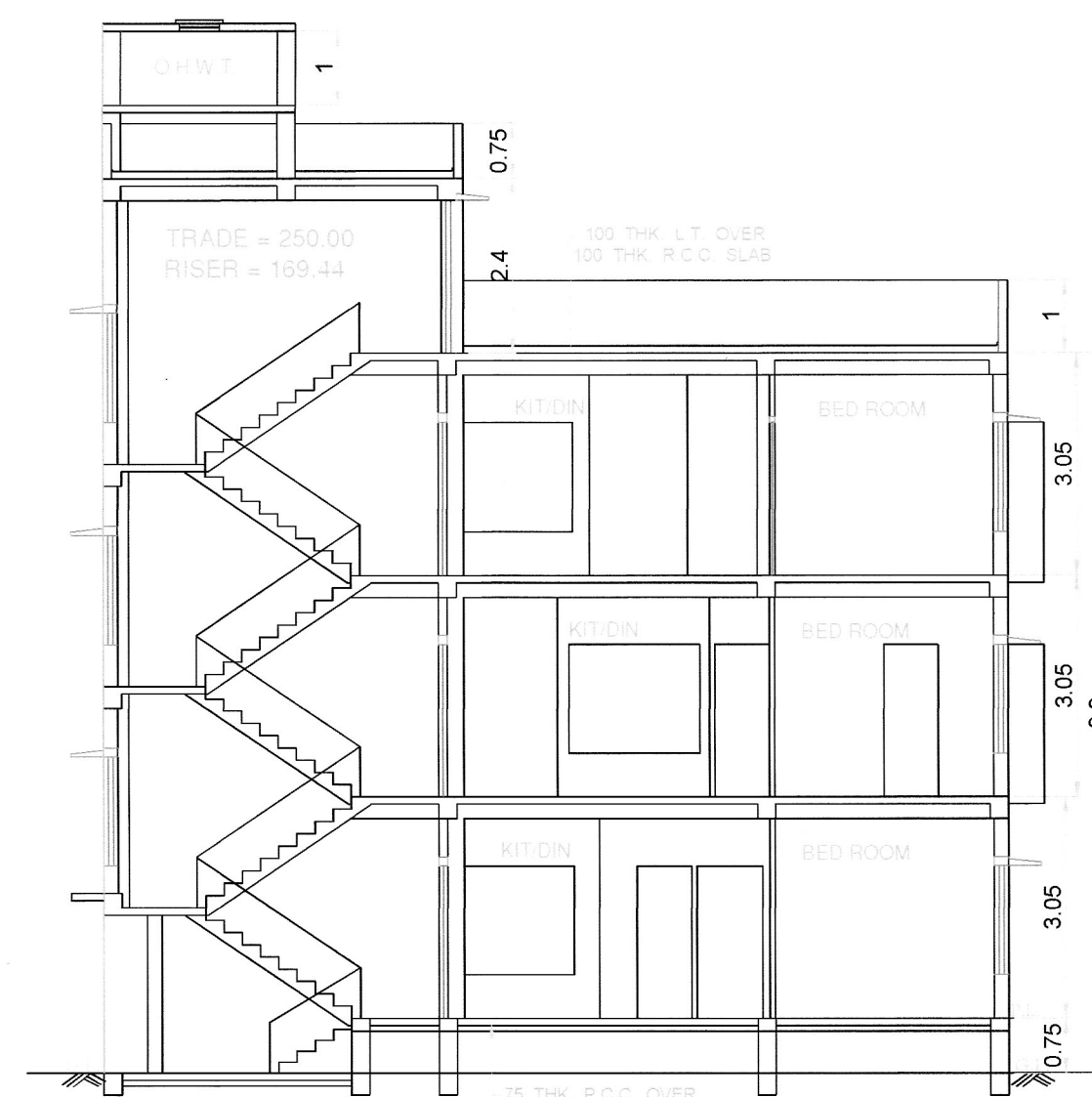

SECTION AT C - D
SCALE - 1:100

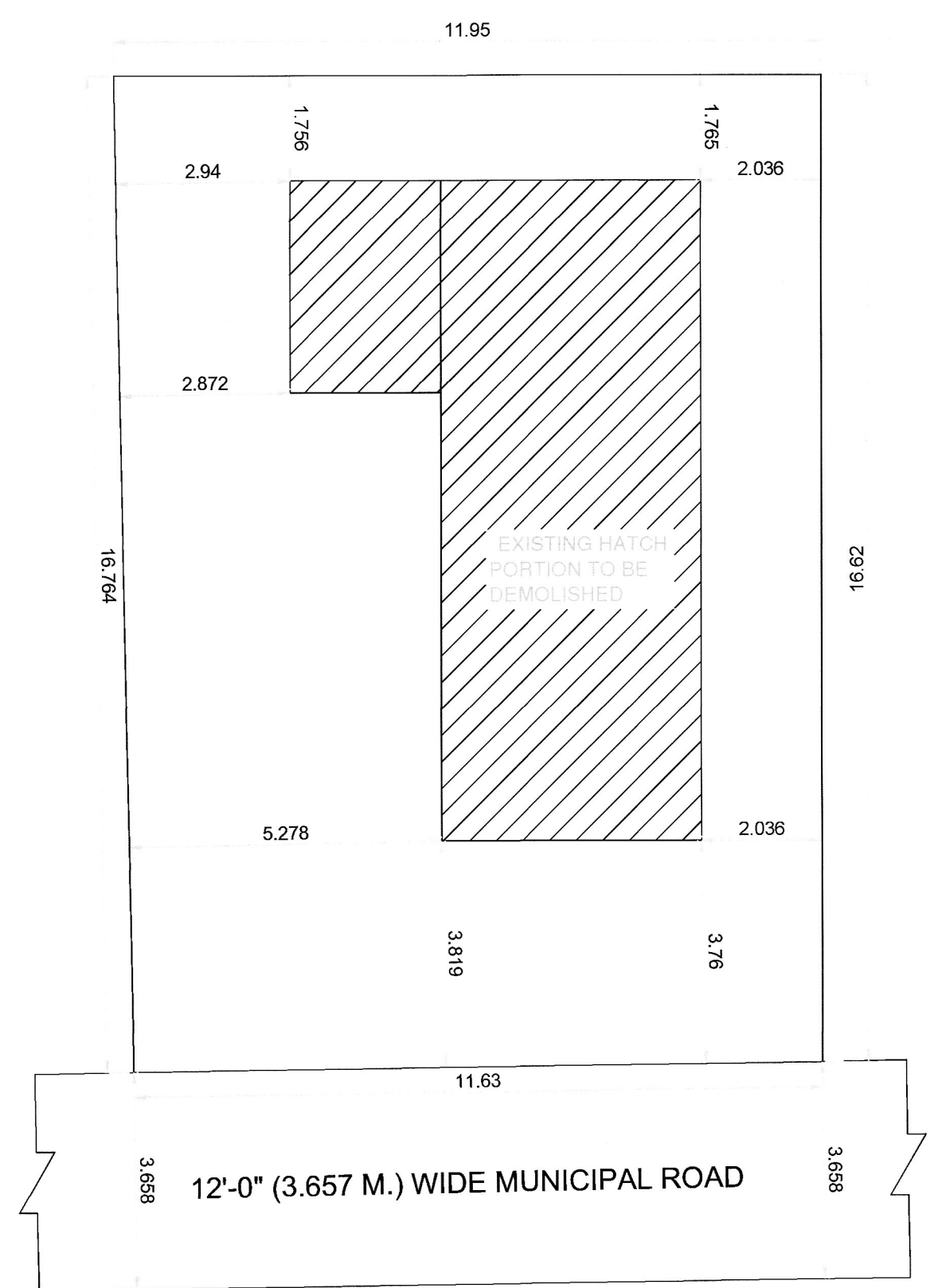

EXIST. GROUND FLOOR PLAN
SCALE - 1:100

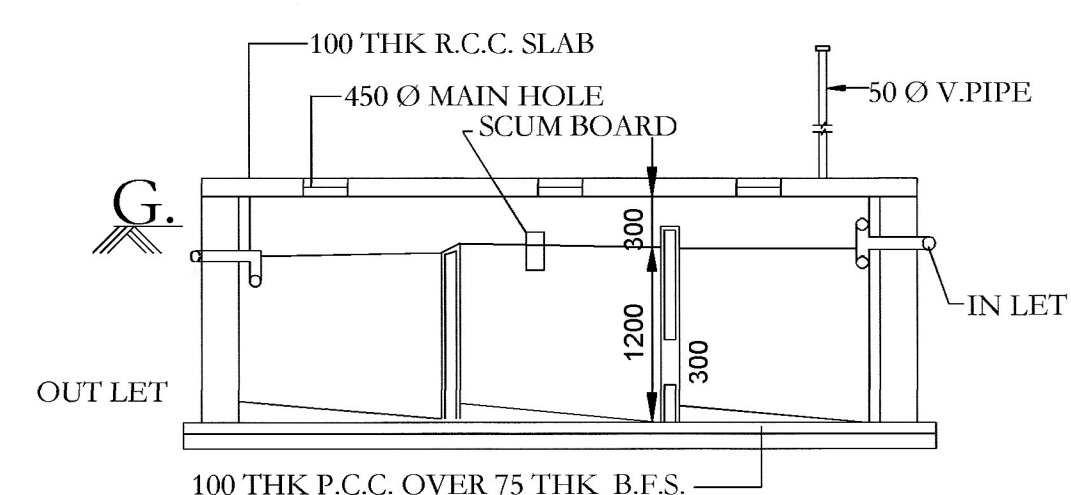

DETAIL OF SEPTICTANK
SCALE = 1:50 (CAPACITY - 30 USER.)=5.80 CUM.

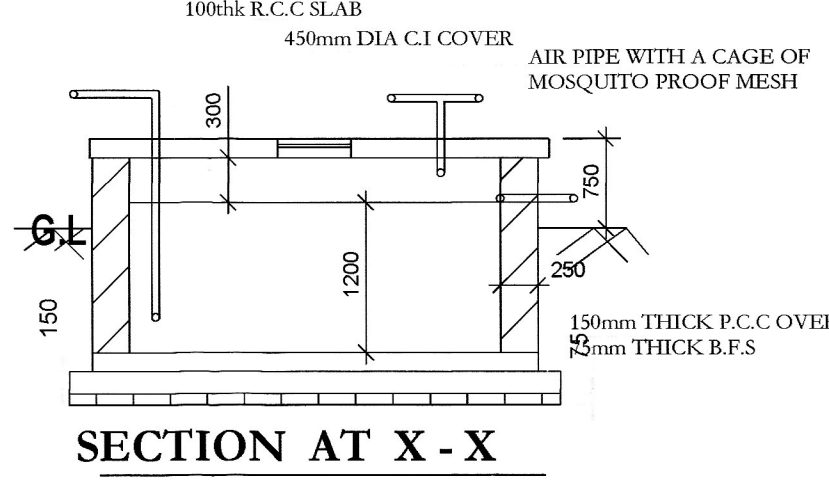

DETAILS S. U. G. W. RESERVOIR
Capacity = 4.5 cum. Scale = 1:50

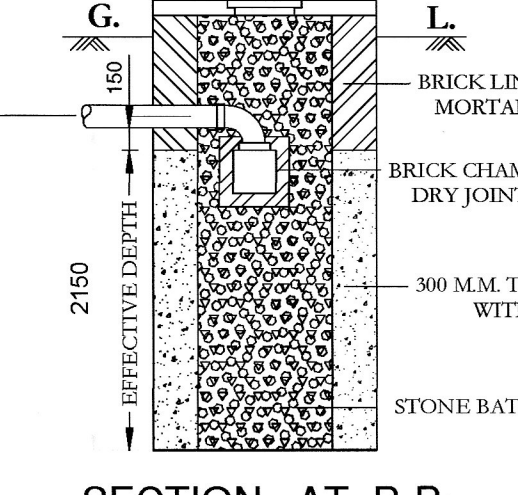

DETAILS OF SOAK-PIT
SCALE - 1:50

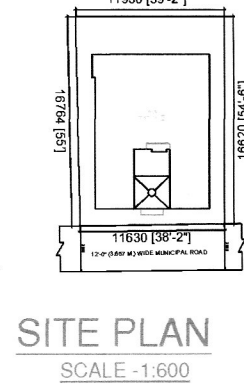

SITE PLAN
SCALE - 1:600

DETAILING OF C.B.

	PERMISSIBLE (SQM)	PROPOSED (SQM)
GR.FLOOR	NIL	NIL
1ST.FLOOR	3.46	2.8
2ND.FLOOR	3.46	2.8
TOTAL	6.92	5.6

TENEMENT AREA :-

TENEMENT MKD.	TENEMENT AREA
A	40.34 Sq.m.
B	32.31 Sq.m.
C	52.31 Sq.m.
D	51.94 Sq.m.
E	59.01 Sq.m.
F	45.24 Sq.m.
TOTAL	281.15 Sq.m.

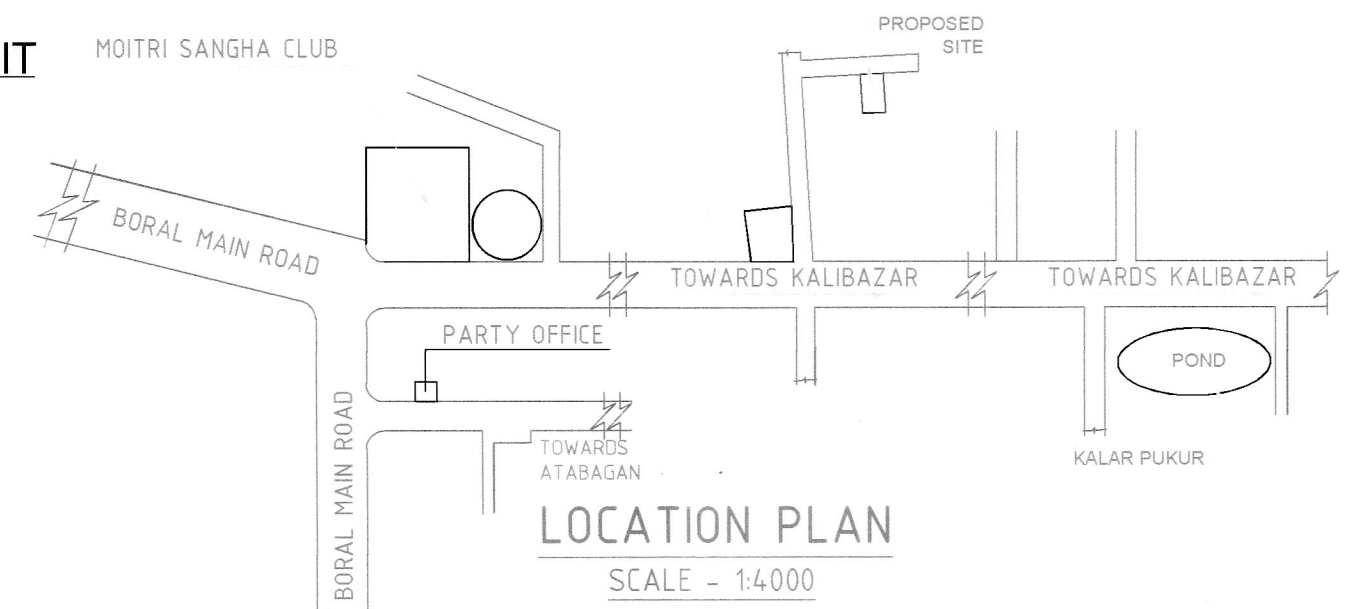

LOCATION PLAN
SCALE - 1:4,000

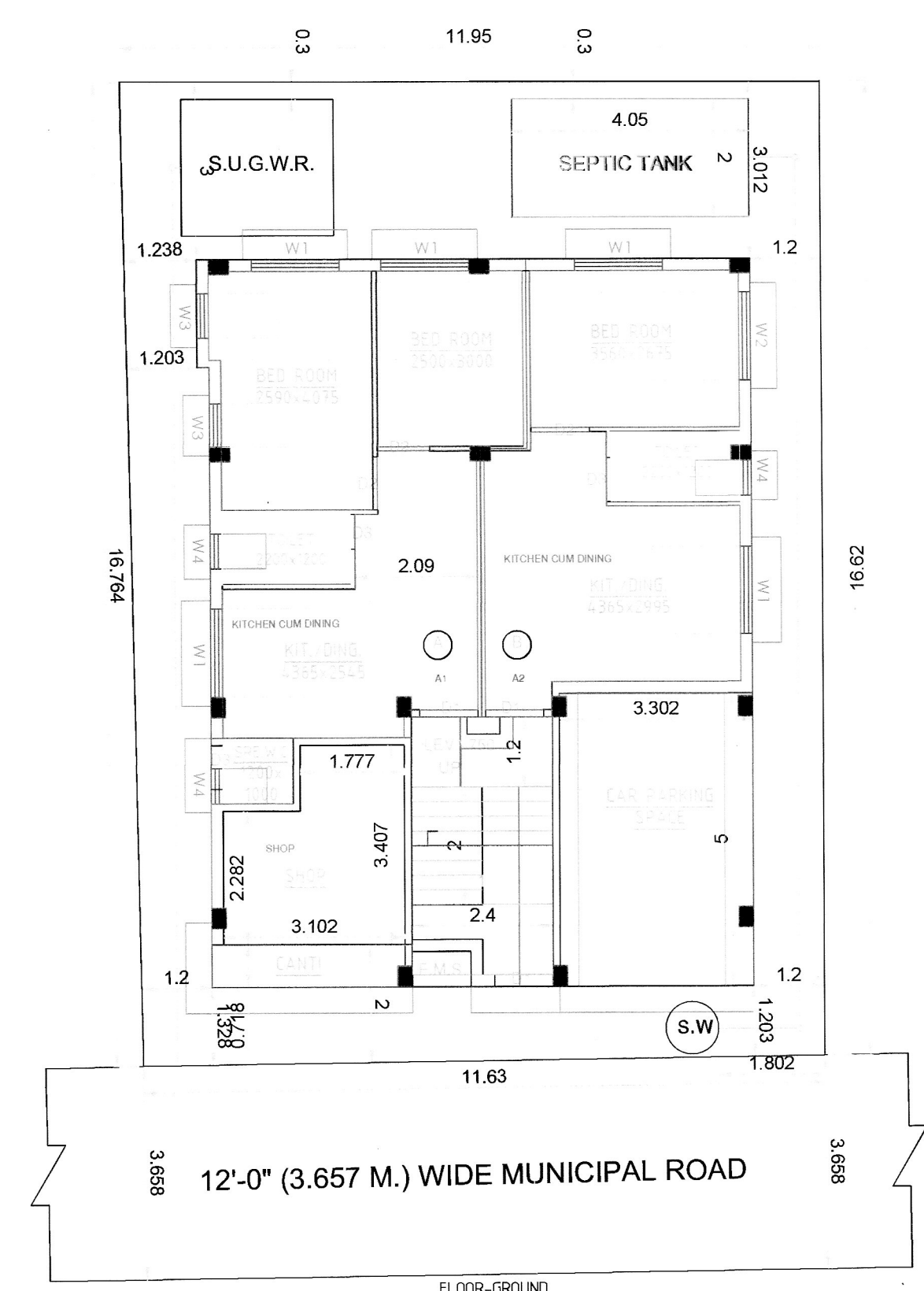

PROPO. GROUND FLOOR PLAN
SCALE - 1:100

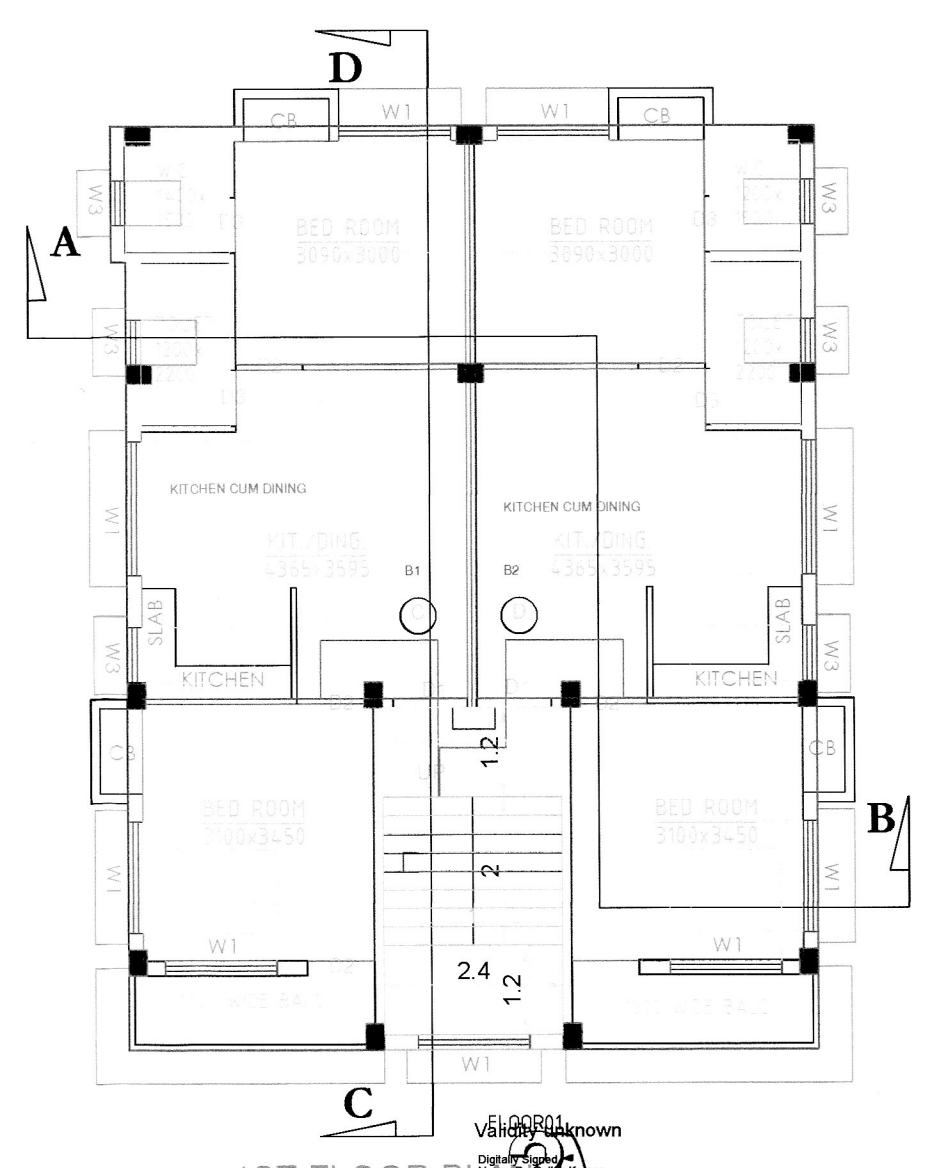

1ST FLOOR PLAN
SCALE - 1:100

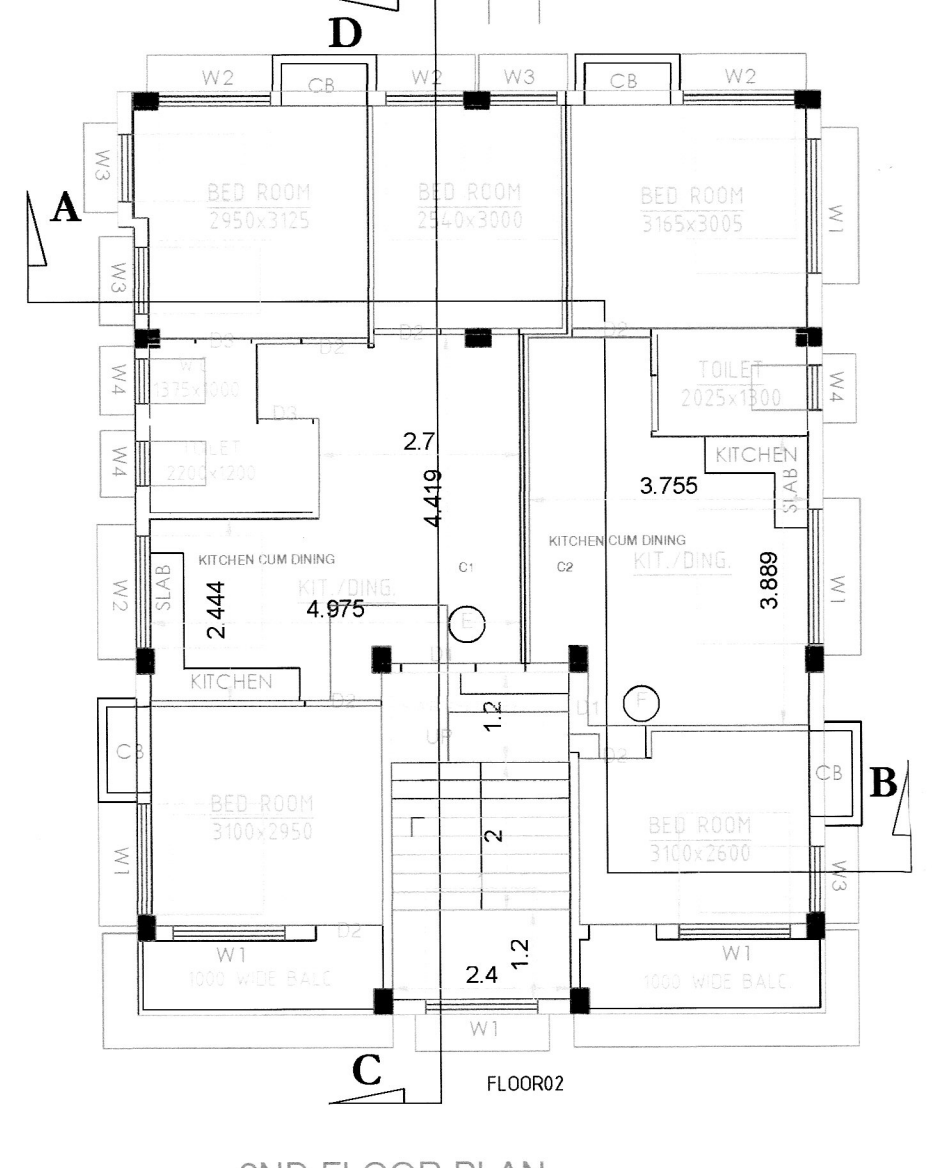

2ND FLOOR PLAN
SCALE - 1:100

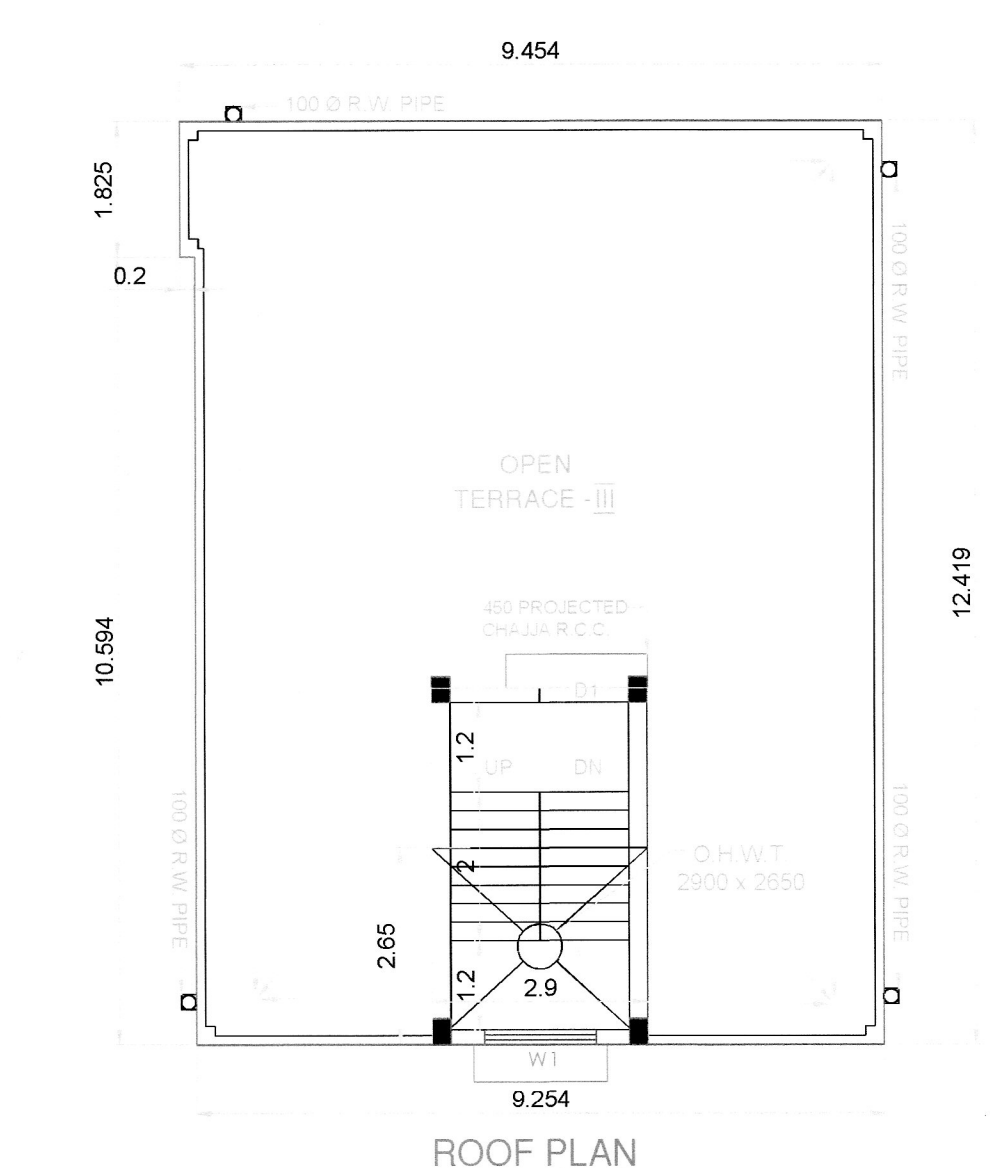

ROOF PLAN
SCALE - 1:100
FLOOR-TERRACE

